

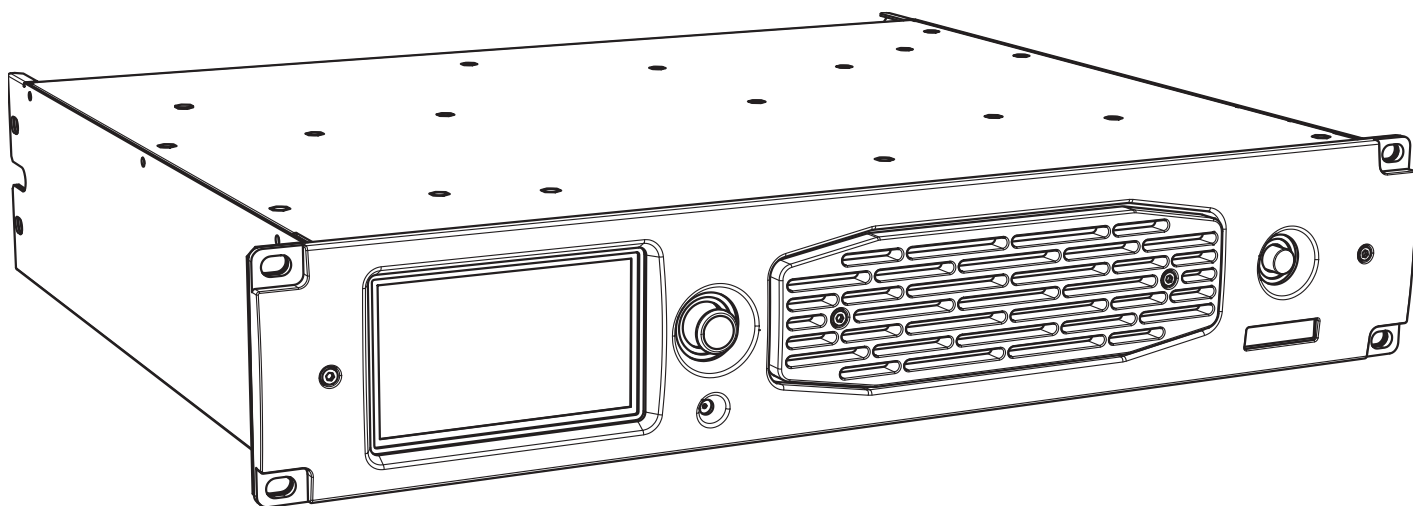

Q-NEX

4-channel Class D power amplifiers with PFC and CORE2 DSP



USER MANUAL

revision 2025-03-06





IMPORTANT SAFETY INSTRUCTIONS

Watch for these symbols:



The lightning flash with arrowhead symbol within an equilateral triangle is intended to alert the user to the presence of uninsulated “dangerous voltage” within the product’s enclosure, that may be of sufficient magnitude to constitute a risk of electric shock to persons.



The exclamation point within an equilateral triangle is intended to alert the user to the presence of important operating and maintenance (servicing) instructions in the literature accompanying the appliance.

1. Read these instructions.
2. Keep these instructions.
3. Heed all warnings.
4. Follow all instructions.
5. Do not use this apparatus near water.
6. Clean only with dry cloth.
7. Do not block any ventilation openings. Install in accordance with the manufacturer’s instructions.
8. Do not install near any heat sources such as radiators, heat registers, stoves, or other apparatus (including amplifiers) that produce heat.
9. Do not defeat the safety purpose of the polarized or grounding-type plug. A polarized plug has two blades with one wider than the other. A grounding-type plug has two blades and a third grounding prong. The wide blade or the third prong are provided for your safety. If the provided plug does not fit into your outlet, consult an electrician for replacement of the obsolete outlet.
10. Protect the power cord from being walked on or pinched, particularly at plugs, convenience receptacles, and the point where they exit from the apparatus.
11. Only use attachments/accessories specified by the manufacturer.
12. Use only with the cart, stand, tripod, bracket, or table specified by the manufacturer, or sold with the apparatus. When a cart is used, use caution when moving the cart/apparatus combination to avoid injury from tip-over.
13. Unplug this apparatus during lightning storms or when unused for long periods of time.
14. Refer all servicing to qualified service personnel. Servicing is required when the apparatus has been damaged in any way, such as power supply cord or plug is damaged, liquid has been spilled or objects have fallen into the apparatus, the apparatus has been exposed to rain or moisture, does not operate normally, or has been dropped.
15. Warning: to reduce the risk of fire or electric shock, do not expose this apparatus to rain or moisture.
16. Do not expose this equipment to dripping or splashing and ensure that no objects filled with liquids, such as vases, are placed on the equipment.
17. To completely disconnect this apparatus from the ac mains, disconnect the power supply cord plug from the ac receptacle.
18. The mains plug of the power supply cord shall remain readily operable.
19. This apparatus contains potentially lethal voltages. To prevent electric shock or hazard, do not remove the chassis, input module or ac input covers. No user serviceable parts inside. Refer servicing to qualified service personnel.
20. The loudspeakers covered by this manual are not intended for high moisture outdoor environments. Moisture can damage the speaker cone and surround and cause corrosion of electrical contacts and metal parts. Avoid exposing the speakers to direct moisture.
21. Keep loudspeakers out of extended or intense direct sunlight. The driver suspension will prematurely dry out and finished surfaces may be degraded by long-term exposure to intense ultra-violet (UV) light.
22. The loudspeakers can generate considerable energy. When placed on a slippery surface such as polished wood or linoleum, the speaker may move due to its acoustical energy output.
23. Precautions should be taken to assure that the speaker does not fall off a stage or table on which it is placed.
24. The loudspeakers are easily capable of generating sound pressure levels (SPL) sufficient to cause permanent hearing damage to performers, production crew and audience members. Caution should be taken to avoid prolonged exposure to SPL in excess of 90 dB.

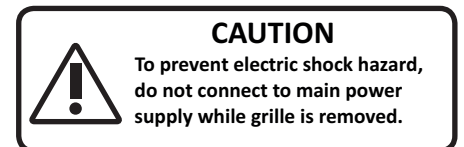

This marking shown on the product or its literature, indicates that it should not be disposed with other household wastes at the end of its working life. To prevent possible harm to the environment or human health from uncontrolled waste disposal, please separate this from other types of wastes and recycle it responsibly to promote the sustainable reuse of material resources. Household users should contact either the retailer where they purchased this product, or their local government office, for details of where and how they can take this item for environmentally safe recycling. Business users should contact their supplier and check the terms and conditions of the purchase contract. This product should not be mixed with other commercial wastes for disposal.



FEDERAL COMMUNICATIONS COMMISSION (FCC) STATEMENT

This equipment has been tested and found to comply with the limits for a Class A digital device, pursuant to part 15 of the FCC Rules. These limits are designed to provide reasonable protection against harmful interference when the equipment is operated in a commercial environment. This equipment generates, uses, and can radiate radio frequency energy and, if not installed and used in accordance with the instruction manual, may cause harmful interference to radio communications.

Operation of this equipment in a residential area is likely to cause harmful interference in which case the user will be required to correct the interference at their own expense.

This device complies with Part 15 of the FCC rules. Operation is subject to the following two conditions:

- (1) this device may not cause harmful interference, and
- (2) this device must accept any interference received, including interference that may cause undesired operation.

DECLARATION OF CONFORMITY

C E The product is in compliance with:
EMC Directive 2014/30/EU, LVD Directive 2014/35/EU, RoHS Directive 2011/65/EU and 2015/863/EU, WEEE Directive 2012/19/EU.

EN 55032 (CISPR 32) STATEMENT

Warning: This equipment is compliant with Class A of CISPR 32. In a residential environment this equipment may cause radio interference. Under the EM disturbance, the ratio of signal-noise will be changed above 10 dB.

UK CA The product is in compliance with:
S.I. 2016/1091 Electromagnetic Compatibility Regulations 2016, S.I. 2016/1101 Electrical Equipment (Safety) Regulations 2016, S.I. 2012/3032 The Restriction of the Use of Certain Hazardous Substances in Electrical and Electronic Equipment Regulations 2012.

CISPR 32 STATEMENT

Warning: This equipment is compliant with Class A of CISPR 32. In a residential environment this equipment may cause radio interference. Under the EM disturbance, the ratio of signal-noise will be changed above 10 dB.

LIMITED WARRANTY

Proel warrants all materials, workmanship and proper operation of this product for a period of two years from the original date of purchase. If any defects are found in the materials or workmanship or if the product fails to function properly during the applicable warranty period, the owner should inform about these defects the dealer or the distributor, providing receipt or invoice of date of purchase and defect detailed description. This warranty does not extend to damage resulting from improper installation, misuse, neglect or abuse. Proel S.p.A. will verify damage on returned units, and when the unit has been properly used and warranty is still valid, then the unit will be replaced or repaired. Proel S.p.A. is not responsible for any "direct damage" or "indirect damage" caused by product defectiveness.

- This unit package has been submitted to ISTA 1A integrity tests. We suggest you control the unit conditions immediately after unpacking it.
- If any damage is found, immediately advise the dealer. Keep all unit packaging parts to allow inspection.
- Proel is not responsible for any damage that occurs during shipment.
- Products are sold "delivered ex warehouse" and shipment is at charge and risk of the buyer.
- Possible damages to unit should be immediately notified to forwarder. Each complaint for package tampered with should be done within eight days from product receipt.

CONDITIONS OF USE

Proel do not accept any liability for damage caused to third parties due to improper installation, use of non-original spare parts, lack of maintenance, tampering or improper use of this product, including disregard of acceptable and applicable safety standards. Proel strongly recommends that this loudspeaker cabinet be suspended taking into consideration all current National, Federal, State and Local regulations. The product must be installed by qualified personal. Please contact the manufacturer for further information.



INDEX

INTRODUCTION	4	10 - OUTPUT 1 - 4	11
SIGNAL PROCESSING	4	11/12- MAINS IN	11
TECHNICAL SPECIFICATION	5	13- FAN	11
SETUP AND RACK MOUNTING	6	Q-NEX DSP OPERATIONS	12
LOUDSPEAKER CABLES	6	1 - SOURCE	12
CONNECTIONS	7	2 - JOIN IN	12
OPTIONAL ACCESSORIES	7	3 - INPUT DSP	12
MECHANICAL DRAWING	8	4 - ROUTING	12
FRONT PANEL	9	5 - JOIN OUT	12
1 - TOUCH DISPLAY	9	6 - OUTPUT DSP	12
2 - DIAL ENCODER/BUTTON	9	7 - BRIDGE	12
3 - FRONT COOLING AIR SLOT	9	8 - Z-LOAD	12
4 - STAND-BY BUTTON	9	9 - NAME	12
5 - FULL RESET HIDDEN BUTTON	9	PRONET AX Network	13
REAR PANEL	10	TOUCH DISPLAY OPERATIONS	14
6 - INPUT 1 - 4	10	HOME SCREEN	14
7 - LINK 1 - 4	10	CHANNEL ROUTING SCREEN	16
8 - NETWORK	10	INPUT SETTING SCREEN	17
9 - TERMINATE BUTTON / LED	10	DEVICE SETTING SCREEN	18
		SPEAKER PROTECTION SETTING	18

INTRODUCTION

Q-NEX are high-performance 4-channel power amplifiers equipped with high-quality DSP, designed both for powering large touring systems and for the use in high-profile fixed installations.

Q-NEX power amplifiers innovative technology is based on a very-high efficiency Class D topology with Switch Mode Power Supply, able to provide up to 20000 W in 4 channels. This technology includes universal power supply with PFC (Power Factor Correction), which guarantees that the performance of the amplifier is always stable, even when the voltage is not. Regardless of any eventual fluctuations of the power supply, Q-NEX amplifiers will always be able to deliver the highest level of power. In addition, an advanced Power Control Management system allows to share the total power of the device between the channels according to needs, having the possibility to obtain in just one channel the maximum power.

Q-NEX technology offers cutting-edge performances, such as better sound definition, high-fidelity reproduction of any frequency of the audio range, higher dynamics at any signal level with low distortion even at very high powers. At the same time, Q-NEX amplifiers feature very compact size and light weight, efficiency above 90% and negligible heat dissipation. The very high efficiency levels result also in a significant reduction in the energy waste associated with large installations, a noticeable reduction in operating costs and a direct benefit to the environment. Featuring high power levels in a lightweight and compact chassis, Q-NEX amplifiers are easy and economical to transport and this, in turn, makes them environmentally friendly.

The extensive protection system includes Soft-start, Turn-on Turn-off transients, Muting at turn-on, Over-heating, DC, RF, Short-circuit, Open or mismatched loads, Overloaded power supply and Clip Limiting.

Q-NEX amplifiers feature an ergonomic and functional up-side-down design to avoid fan dust accumulation, plus removable dust filters for an easy maintenance in all conditions of use and therefore extensive durability.

SIGNAL PROCESSING

The Q-NEX system processing is based on the CORE2 DSP platform designed by the PROEL R&D Laboratories using one of the most advanced SHARC DSP devices available for audio applications. It features 40bit, floating point resolution and top-quality 24-bit AD/DA converters for perfect signal integrity, dynamic range in excess of 110dB and superior sonic performance. Thanks to its massive processing power, the CORE platform is capable of providing the most sophisticated algorithms for speaker processing, including linear phase FIR filters, together with comprehensive remote control and networking capabilities.

The Q-NEX amplifiers' DSP section includes a full set of functions on each input and output. Each INPUT features 5 bands of full PARAMETRIC EQ, a 1024 taps FIR filter, a fully programmable COMPRESSOR/LIMITER and up to 600ms of input delay. Each OUTPUT includes any kind of crossover filter with slope up to 48dB per octave, together with 10 bands of PEQ, two fully programmable COMPRESSOR/LIMITER, up to 300ms of output delay and 3 bands of an extremely versatile and powerful DYNAMIC EQ.

A very flexible ROUTING MATRIX allows each of the physical analog inputs to be routed to any of the 4 digital inputs, and any digital input to be routed to any of the 4 power outputs.

The PRONET AX control software, working on a solid and reliable CANBUS based network protocol, provides an intuitive interface for the remote control of the whole audio system via the rear panel etherCON RJ45 connectors, with the possibility to setting all processing parameters and monitoring the status of the amplifier.



TECHNICAL SPECIFICATION

MODEL	Q-NEX5.4	Q-NEX10.4	Q-NEX14.4	Q-NEX20.4
Channels	4	4	4	4
Total Output Power	5000 W	10000 W	14000 W	20000 W
Output Power* (All ch driven/single ch)				
2 ohms	4x1250 / 1x1250 W	4x2500 / 1x2500 W	4x3500 / 1x3500 W	4x5000 / 1x5000 W
2.67 ohms	4x1250 / 1x1700 W	4x2500 / 1x3300 W	4x3500 / 1x4700 W	4x5000 / 1x6700 W
4 ohms	4x1250 / 1x2500 W	4x2500 / 1x2500 W	4x3500 / 1x3750 W	4x5000 / 1x6000 W
8 ohms	4x1250 / 1x1250 W	4x1250 / 1x1300 W	4x1800 / 1x1900 W	4x2500 / 1x3000 W
4 ohms Bridged	2x2500 W	2x5000 W	-	-
8 ohms Bridged	2x2500 W	2x5000 W	-	-
Hi-Z 100V	4x1250 / 1x2500 W	4x2500 / 1x2500 W	4x3500 / 1x4200 W	4x5000 / 1x5000 W
Hi-Z 70V	4x1250 / 1x1800 W	4x2500 / 1x2500 W	4x2950 / 1x2950 W	4x3500 / 1x3500 W
Max output voltage	150 Vpeak	150 Vpeak	189 Vpeak	235 Vpeak
Max output current	36 Apeak	50 Apeak	59 Apeak	71 Apeak
Frequency response	20 Hz - 20 kHz			
Input Sensitivity (DSP adjustable)	+10 dBu	+10 dBu	+12 dBu	+14 dBu
Gain	32 dB	32 dB	32 dB	32 dB
Input Impedance	30 Kohm (bal) / 15 Kohm (unbal)			
Input Connectors	INPUT: XLR-F LINK: XLR-M			
Output Connectors	NL4 Speakon			
Network Connectors	2 x ETHERCON®(NE8FAV)			
Signal Processing	CORE2 processing, 40bit floating point SHARC DSP, 24 bit AD/DA converters			
Direct access Controls	Capacitive touch panel - Dial - Terminate			
Remote Controls	PRONET AX control software			
Cooling	Variable speed DC fan			
Protections	Soft-start, Turn-on Turn-off transients, Muting at turn-on, Over-heating, DC, RF, Short-circuit, Open or mismatched loads, Overloaded power supply, Clip Limiting			
S/N Ratio	111 dBA	111 dBA	113 dBA	115 dBA
THD+N	< 0.05 %			
Power Supply	100V - 240 V~, 50Hz-60Hz			
Current Absorption (230 V~ - 4 ohm - 1/8 Rated Power)	3.7 A	7.3 A	10 A	14 A
Current Absorption (120 V~ - 4 ohm - 1/8 Rated Power)	7.2 A	14 A	19.2 A	26.8 A
Current Absorption (100-240 V~ - idle state)	0.7 A	0.7 A	1 A	1 A
Thermal Dissipation (4 ohm - 1/8 Rated Power)	655 BTU/h 165 kCal/h	1310 BTU/h 330 kCal/h	1834 BTU/h 462 kCal/h	2620 BTU/h 660 kCal/h
Weight Net (kg-Lb)	7 kg (15.4 lbs)	7 kg (15.4 lbs)	9 kg (19.8 lbs)	9 kg (19.8 lbs)
Dimensions (W x H x D)	483x89x355 mm (19"x3.5"x14")			

* IEC filtered pink noise signal (40Hz-5kHz, 12dB crest factor)



SETUP AND RACK MOUNTING



To ensure proper air circulation the amplifiers must be installed as shown in the figures below. The dust filter on the front panel should be checked and cleaned periodically

RECOMMENDED INSTALLATION ON 8U OPEN RACK

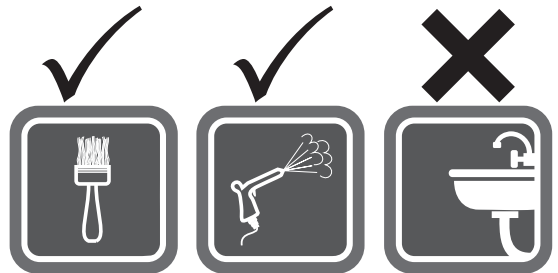
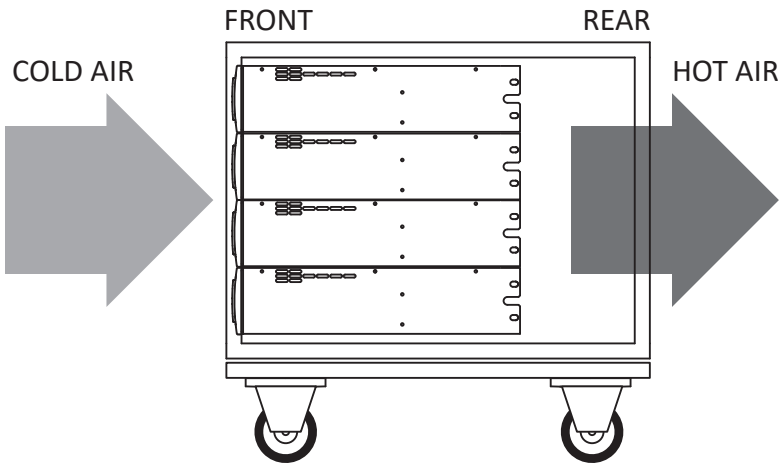

EVENTUAL INSTALLATION ON 10U CLOSED RACK

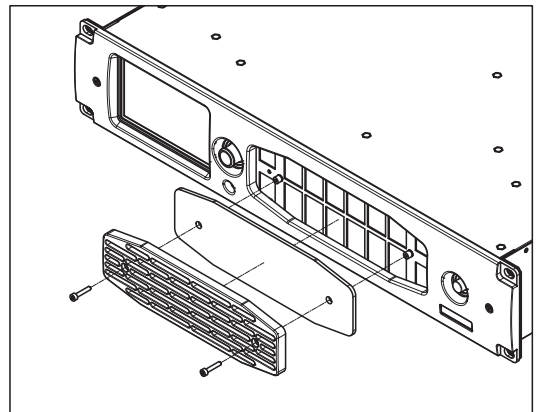
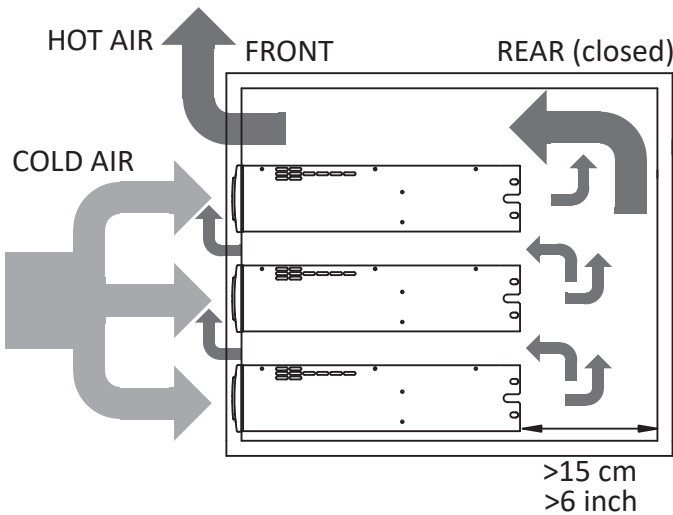

LOUDSPEAKER CABLES

The following table suggests a list of cables and the maximum length for the typical 4 and 8 ohm load and 100V line.

Loudspeaker Line Losses (maximum line lengths allowed for 0.5dB losses, voltage or spl)														
2 ohm load		4 ohm load		8 ohm load		100V line		Wire section data		PROEL recommended cables				
feet	meter	feet	meter	feet	meter	feet	meter	mm ²	AWG	2 wires	2w Fire r.	Speakon 2	4 wires	Speakon 4
39	12	82	25	164	50	2066	630	4.0	12	HPC624BK	HPC624HF	NL2FXXWS	HPC644	NL4FXXWL
26	8	52	16	105	32	1279	390	2.5	13	HPC620BK	HPC620HF	NL2FXXWS	HPC640BK	NL4FXXWS
16	5	33	10	66	20	771	235	1.5	16	HPC610BK	-	NL2FXXWS	-	-

Cables and connectors currently available from PROEL at printing time of this manual.



CONNECTIONS

INPUT

Balanced male XLR

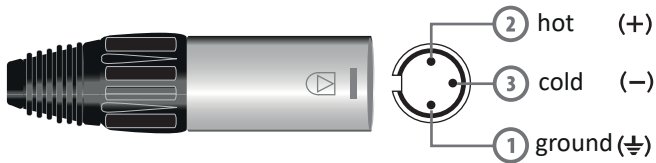

LINK

Balanced female XLR

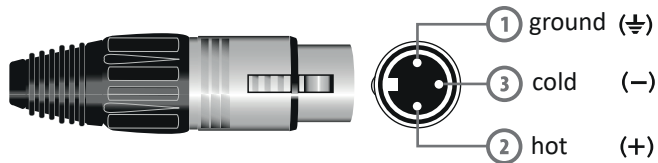

SPEAKER OUTPUT

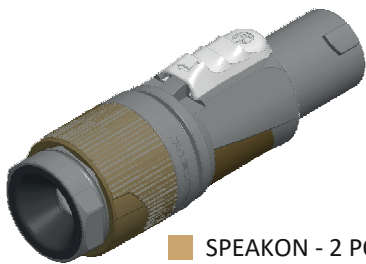

SPEAKON - 2 POLES
NL2FXXWS - Ø 6-12mm cables

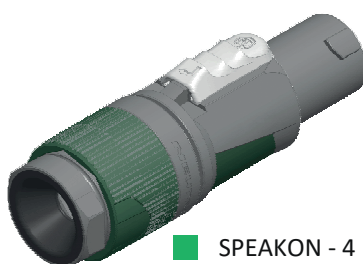

SPEAKON - 4 POLES
NL4FXXWS - Ø 6-12mm cables
NL4FXXWL - Ø 10-16mm cables

A) Place the bushing (1) and the chuck (2) over the cable

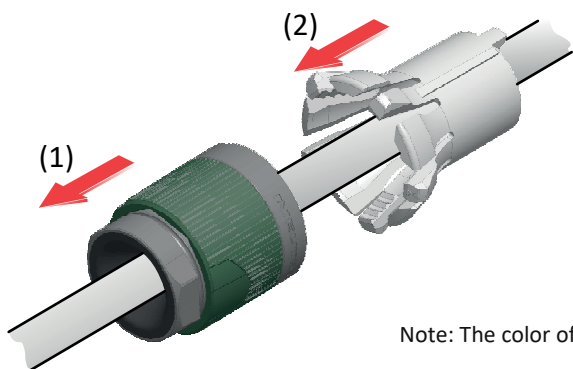

B) Prepare the cable as shown

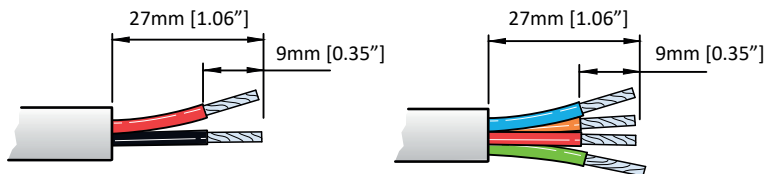

Note: The color of the wires is indicative, but respect the same color on both sides of the cable.

C) Slide the cable into the contacts and clamp

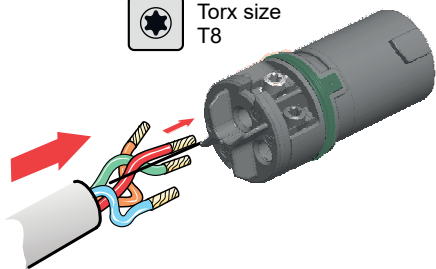

CH1, CH2, CH3, CH4
WIRING: 2 POLE

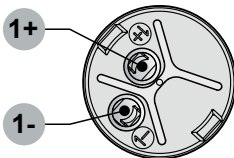

CH1-2, CH3-4
WIRING: 4 POLE

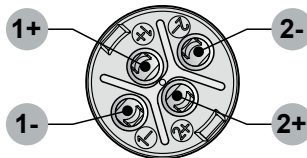

CH1 BRIDGE, CH3 BRIDGE
WIRING: 2 POLE

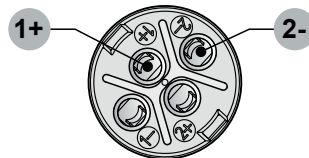

OPTIONAL ACCESSORIES

NC3MXX	Neutrik XLR-M
NC3FXX	Neutrik XLR-F
NL2FXXWS	Neutrik Speakon 2 poles
NL4FXXWS	Neutrik Speakon 4 poles 6-12mm
NL4FXXWL	Neutrik Speakon 4 poles 10-16mm
CAT5SLU01/05/10	1x Cat5e with NEUTRIK connectors, 1/5/10 m length

NAC3FXXA-W-S	Neutrik Powercon BLUE PLUG (Q-NEX 5.4/10.4)
NAC3FC-HC	Neutrik Powercon 32A PLUG (Q-NEX 14.4/20.4)
NE8MX	RJ45 shell for pre-assembled cable
NE8MX1	RJ45 shell for not pre-assembled cable
USB2CANDV2	Dual output PRONET AX network converter
AVCAT5PROxx	Cat5e on cable drum, RJ45 plugs and NEUTRIK connectors 30/50/75 m length

see <http://www.axiomproaudio.com/> for detailed description and other available accessories.



MECHANICAL DRAWING

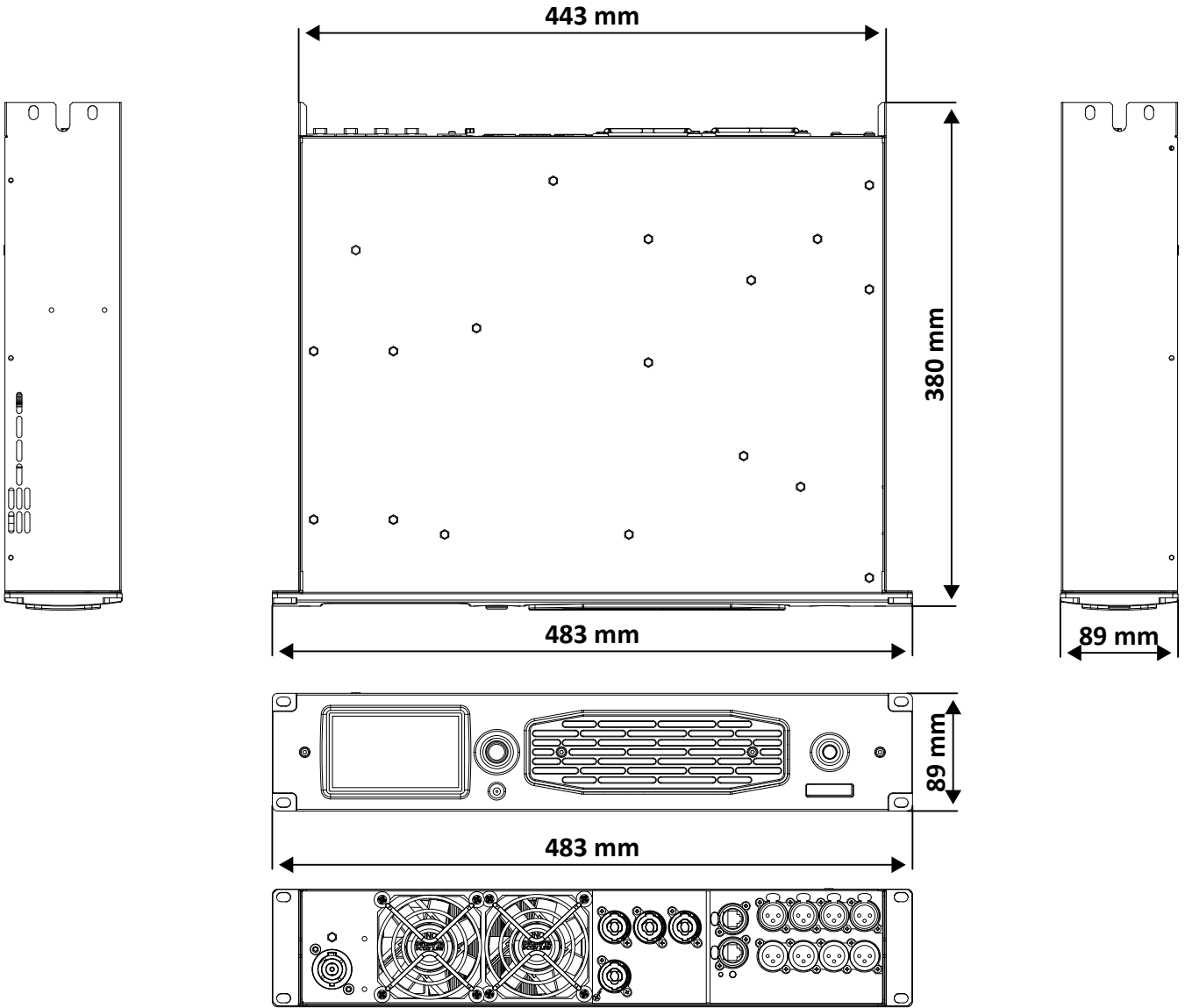



FRONT PANEL

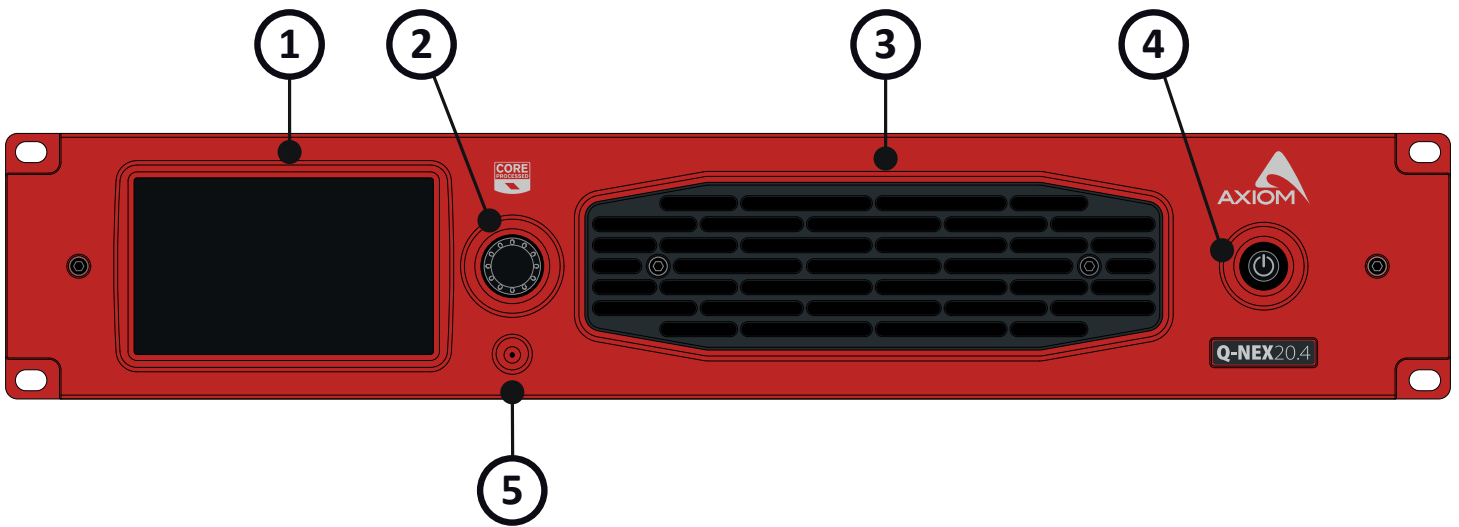

1 - TOUCH DISPLAY

This is an IPS display with capacitive touch panel that allows you to view and change the main parameters of the amplifier (see below for a detailed explanation).

2 - DIAL ENCODER/BUTTON

Pressing and turning this dial allows you to change the parameters of the amplifier currently selected on the display.

3 - FRONT COOLING AIR VENT

This is the opening through which air flows to cool the amplifier. It is equipped with a removable dust filter that must be cleaned periodically to ensure proper cooling.

4 - STAND-BY BUTTON

Pressing it for a few seconds turns the amplifier on or off. When it is lit up in YELLOW it means that mains power is present but the amplifier is in stand-by mode, also confirmed by the black display. When it is lit up in GREEN it means that the amplifier is on and fully operational, also confirmed by the activity of the display.

5 - FULL RESET HIDDEN BUTTON

This hidden button, that can be pressed using a small pin, resets the DSP parameters to factory defaults, completely erasing all preset memories. It is usually not necessary to use this button, unless you need to completely erase all the DSP parameters and set them again from scratch or reload them from PRONET AX.



REAR PANEL

Q-NEX5.4 / Q-NEX10.4

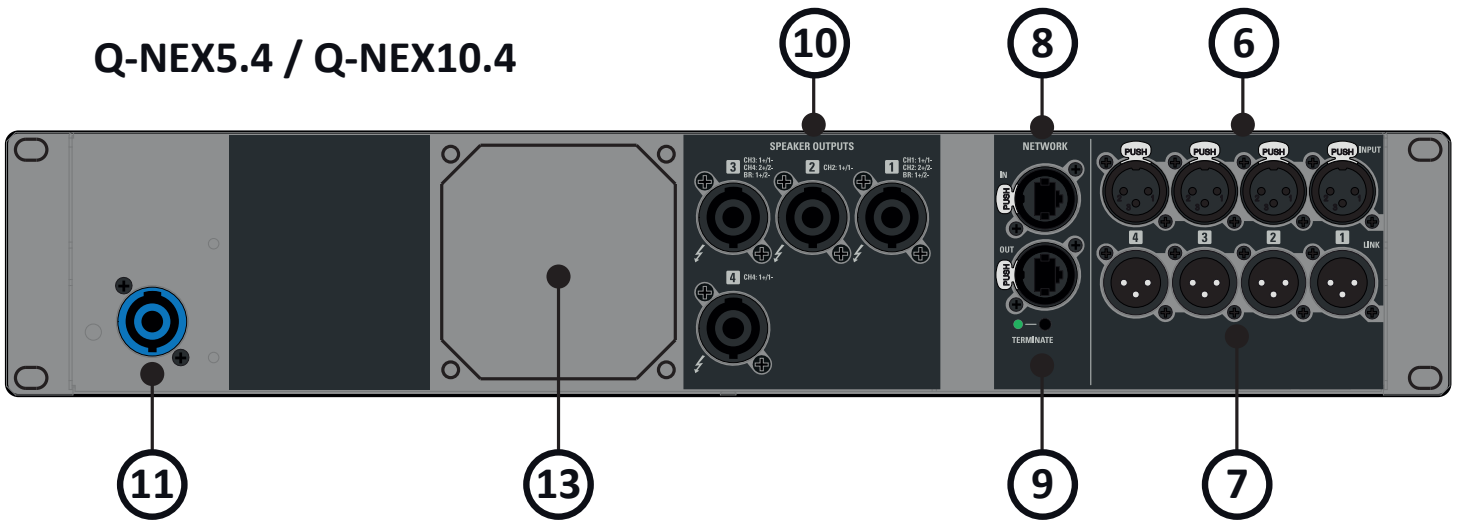

Q-NEX14.4 / Q-NEX20.4

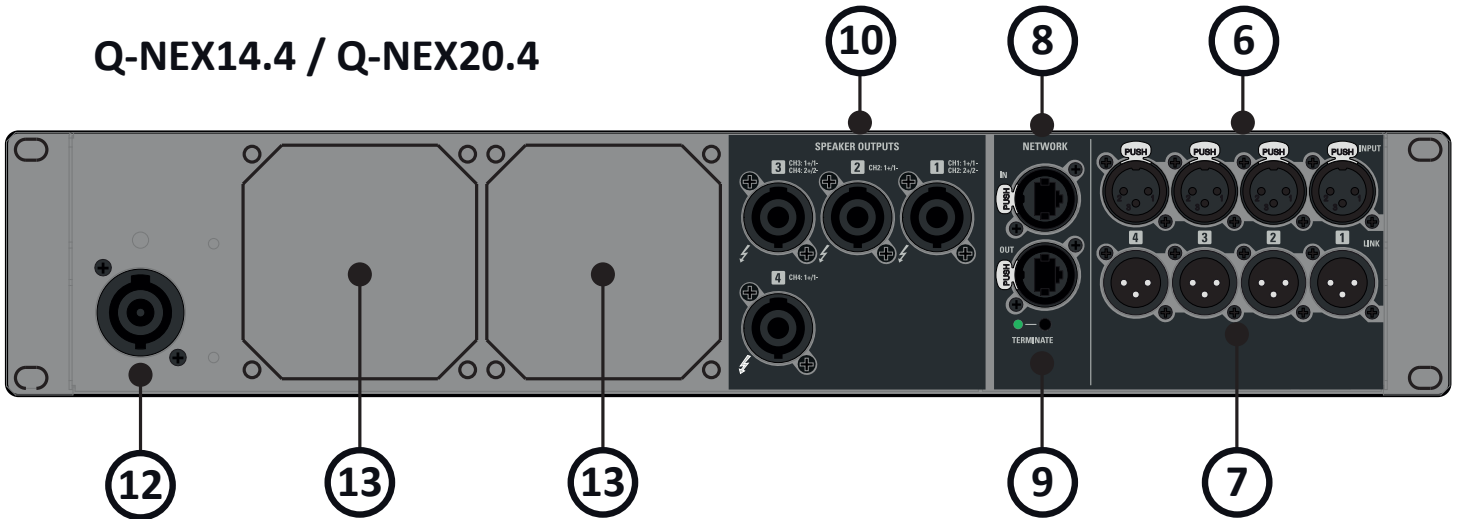

6 - INPUT 1 - 4

These are the balanced audio signal inputs with locking XLR connectors. Each input has a fully electronically balanced circuitry including AD conversion for the best S/N ratio and input headroom. Each input can be processed and routed internally by the DSP to drive one or more of the four amplifier channels (see further for detailed information).

Use only balanced audio signals to obtain the best performances.

7 - LINK 1 - 4

A direct link from the input connector to feed other amplifiers with the same audio signal.

8 - NETWORK IN / OUT

These are two standard RJ45 CAT5 connectors used to connect the amplifiers to the PRONET AX “bus-topology” network: see **PRONET AX Network section** below for detailed instructions.

9 - TERMINATE BUTTON / LED

This button allows you to terminate the last Q-NEX unit in a PRONET AX network: the LED lights up yellow when terminate button is pressed. See **PRONET AX Network section** below for detailed instructions.



10 - OUTPUT 1 - 4

These are the four SPEAKON connectors that allows to connect the four internal amplifiers to the speakers. Each SPEAKON has a different connection:

SPEAKON	amplifier channel	standard	bridge*
1	CH1+ positive CH1- negative CH2+ positive CH2- negative	1+ 1- 2+ 2-	1+ nc nc 2-
2	CH2+ positive CH2- negative	1+ 1-	
3	CH3+ positive CH3- negative CH4+ positive CH4- negative	1+ 1- 2+ 2-	1+ nc nc 2-
4	CH4+ positive CH4- negative	1+ 1-	

nc = do not connect any wire.

* available on Q-NEX5.4 and Q-NEX10.4 only.

11/12- MAINS IN

This connector is where you plug in the mains cord supplied with the device. Depending on the amplifier type two different connectors are used:

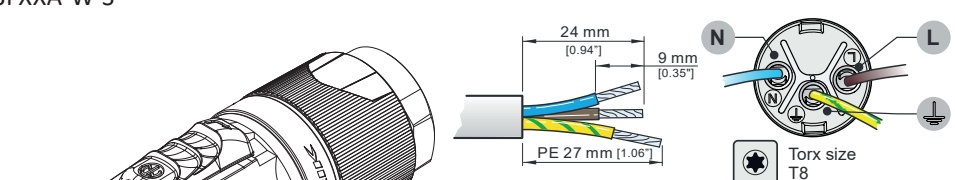
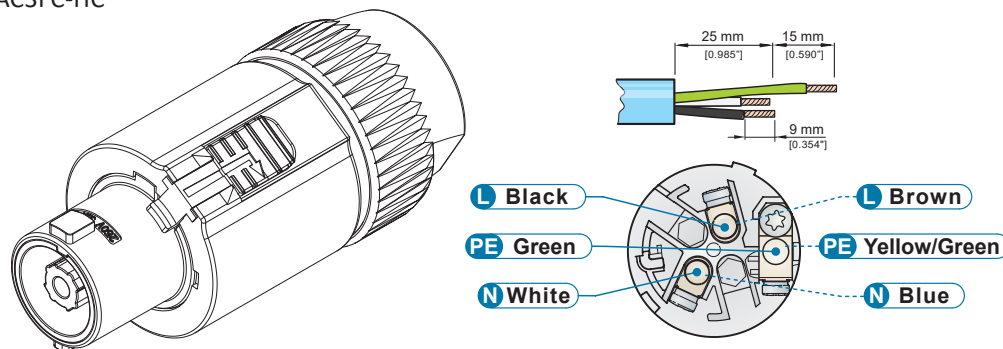
<p>(11) Q-NEX5.4 / Q-NEX10.4</p>	<p>NAC3FXXA-W-S</p>  <table border="1" data-bbox="909 1176 1404 1366"> <thead> <tr> <th>Typical Wiring</th> <th>IEC/EN 60230-1</th> <th>UL60320-1 CAN/CSA-C22.2 No. 60320-1</th> </tr> </thead> <tbody> <tr> <td>L</td> <td>brown</td> <td>black</td> </tr> <tr> <td>N</td> <td>blue</td> <td>white</td> </tr> <tr> <td>PE</td> <td>green/yellow</td> <td>green</td> </tr> </tbody> </table>	Typical Wiring	IEC/EN 60230-1	UL60320-1 CAN/CSA-C22.2 No. 60320-1	L	brown	black	N	blue	white	PE	green/yellow	green
Typical Wiring	IEC/EN 60230-1	UL60320-1 CAN/CSA-C22.2 No. 60320-1											
L	brown	black											
N	blue	white											
PE	green/yellow	green											
<p>(12) Q-NEX14.4 / Q-NEX20.4</p>	<p>NAC3FC-HC</p> 												



WARNING

Each amplifier is supplied with a pre-assembled cable for the CE market with a SCHUKO CEE 7/4 type F plug for the European 230V AC standard operation. Any other plug type or mains cable assembly is under responsibility of the user.

13- FAN

These are the air vents for the internal fan(s): keep them always clean and free from any obstacle, including rear cables.



Q-NEX DSP OPERATIONS

The PRONET AX software must be used to control the Q-NEX amplifiers' built-in CORE2 DSP.

All features of the CORE2 DSP are described in the **PRONET AX user manual** (see the HELP menu), so only some peculiarities of the Q-NEX amplifiers architecture are explained in this manual.

The internal DSP architecture follows the block diagram below:

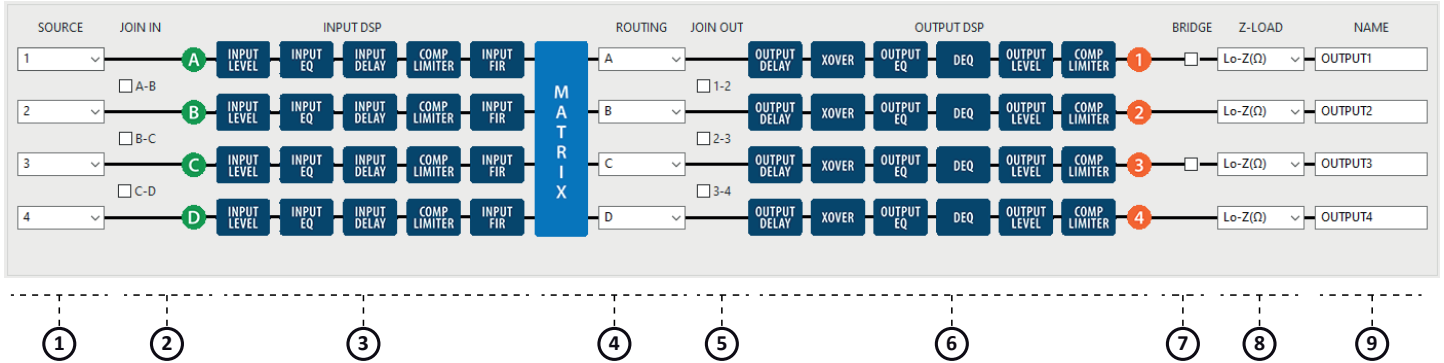

1 - SOURCE

These are the physical XLR inputs. Each physical input (1, 2, 3, 4) can be assigned to each of the four DSP INPUTS (A, B, C, D), separately or combined together (1+2, 3+4, 1+2+3+4).

2 - JOIN IN

By checking these boxes allows you to join the parameters of A-B, B-C, C-D, DSP INPUTS, so changing a DSP INPUT parameter also the joined parameter will be changed accordingly.

3 - INPUT DSP

These are the four DSP INPUT processors (A, B, C, D). Each INPUT has 5 blocks: INPUT LEVEL, COMP LIMITER, INPUT EQ, INPUT DELAY, INPUT FIR. A detailed explanation of each block can be found in the PRONET AX manual.

4 - ROUTING

Using this matrix section the four DSP INPUTS (A, B, C, D) can be assigned singularly or combined (A+B, C+D, A+B+C+D) to the DSP OUTPUTS (1, 2, 3, 4).

5 - JOIN OUT

By checking these boxes allows you to join the parameters of 1-2, 2-3, 3-4, DSP OUTPUTS, so changing a DSP OUTPUT parameter also the joined parameter will be changed accordingly.

6 - OUTPUT DSP

These are the four DSP OUTPUTS. Each OUTPUT has 6 blocks: OUTPUT DELAY, XOVER, OUTPUT EQ, DEQ, OUTPUT LEVEL, COMP LIMITER. A detailed explanation of each block can be found in the PRONET AX manual.

7 - BRIDGE

By checking these boxes allows you to set the 1-2 or 3-4 channels in bridge mode. When set as bridge, automatically the parameters of the second channel (2 or 4) disappear. *Note: the bridge mode is available on Q-NEX5.4 and Q-NEX10.4 models only.*

8 - Z-LOAD

By checking these boxes allows you to set the channels to operate in LO-Z, HI-Z 100V or HI-Z 70V mode. The HI-Z operation can be set using PRONET AX only.

9 - NAME

In these boxes you can enter a 10 character custom name for each OUTPUT. This name appears on the display of the device.



PRONET AX Network

Q-NEX amplifiers can be connected in a network and controlled by the PRONET AX software. For the network connection the **USB2CAND** USB to CAN converter (optional) is needed. PRONET AX software has been developed in collaboration with sound engineers and sound designers to offer an “easy-to-use” tool to setup and manage your audio system. With PRONET AX you can visualize signal levels, monitor internal status and edit all the parameters of each connected device.



Download the **PRONET AX** control software registering on **MY AXIOM** at the website <https://www.axiomproaudio.com/>.

PRONET AX network is based on a “bus-topology” connection, where the each device is connected sequentially to the next. To ensure a reliable communication the first and the last devices, which have a single connection, must be terminated. This can be done by pressing the “TERMINATE” switch near the network connectors of the first and the last device. For the PRONET AX network connections simple RJ45 cat.5 or cat.6 Ethernet cables can be used.



IMPORTANT: do not confuse the PRONET AX network with an Ethernet network. They are completely different and must be completely separate, even if they both use the same type of cable.

Assign the ID number

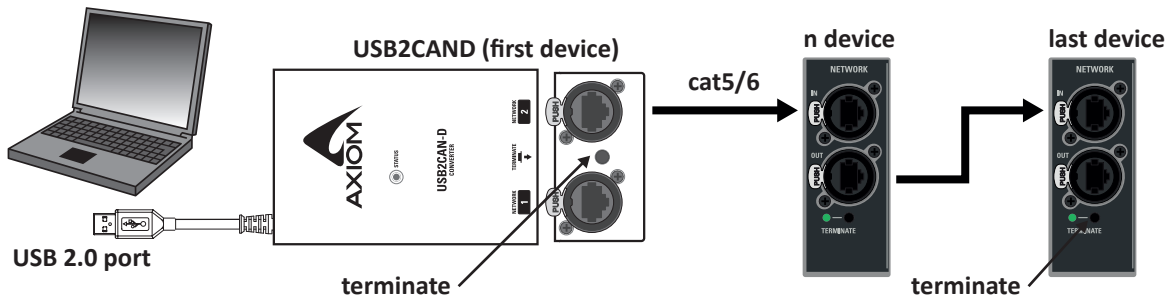

To work properly in a PRONET AX network each connected device must have a unique identifier number, called ID. By default the USB2CAND converter has ID=0 and there can be only one converter. Every other device connected must have its own unique ID equal or greater than 1: in the network cannot exist two devices with the same ID.

To correctly assign an ID to each Q-NEX device in a Pronet AX network you have to follow these instructions.

Manual ID assign - Local:

1. Switch on the single amplifier.
2. In the SETTINGS page of the LCD menu set “ID ASSIGN” with a different and unique ID for each amplifier.

Auto ID assign - Local

1. Switch on all the amplifiers.
2. Connect all the amplifiers with the network cable.
3. In the SETTINGS page of each Q-NEX amplifier device set “ID ASSIGN” as “AUTO-ID”: a different ID will be assigned automatically to at each amplifier.

NOTE: the “AUTO-ID” procedure for a device makes the internal network controller to reset the current ID and to search for the first free ID in the network starting from ID=1. If no other devices are connected (and powered on), the controller assume ID=1, that is the first free ID, otherwise it searches for the first one free.

Manual ID assign from - PRONET AX

1. Switch on the single amplifier.
2. Connect the single amplifier to PRONET AX using USB2CAND converter.
3. Run PRONET AX and set it “ONLINE”.
4. Select **File/Tools/Remote ID Change** and assign a different and unique ID for each amplifier.



If your network is always composed of the same devices, the ID assign procedure must be executed only the first time the system is turned on.

These operations ensure that every device has it’s own unique ID. If you need to add a new device to the network, you simply repeat the operation. Every device maintains its ID also when it is turned-off, because the identifier is stored in the internal memory and it is cleared only by another “Assign ID” step, as explained above.





LCD OPERATIONS

The LCD menu has 4 pages (HOME, ROUTING, INPUT, DEVICE) that allow you to check the amplifier's current status and to change a limited set of parameters, like recalling a preset, muting the channels, setting the level and so on. A full control of the amplifier parameters is possible only with Pronet AX software.

When Pronet AX is connected, it has the full control of the device and the LCD shows only a locked home page: the first row shows the connection info in red colour and, if you touch the screen or rotate/press the dial, a warning message appears.

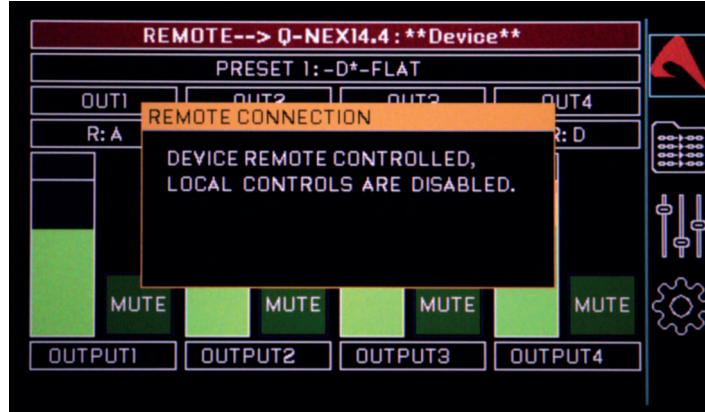

HOME PAGE

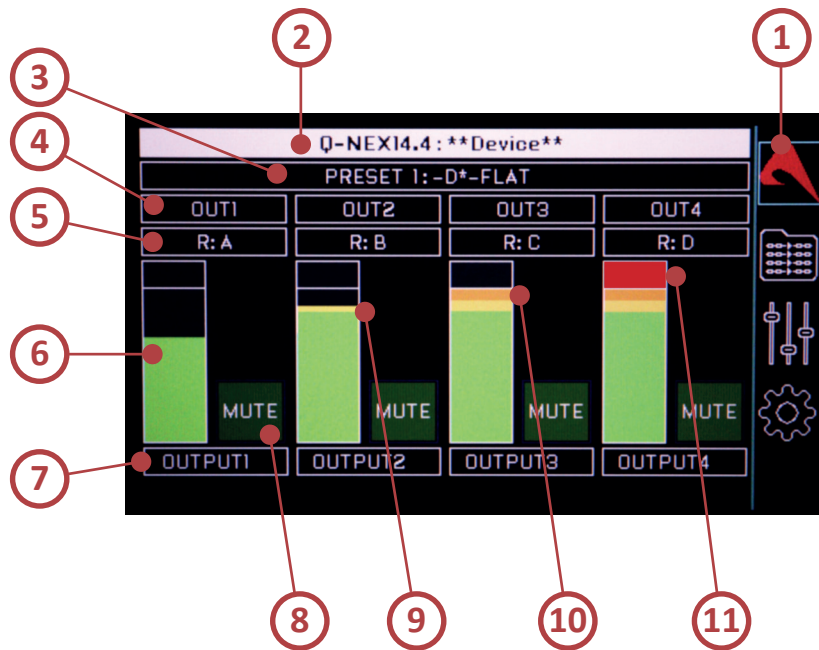

- 1 This column shows which page of the menu is active. To select the page, touch the screen or use the dial. The available pages are HOME (Axiom logo), ROUTING (folder), INPUT (faders), DEVICE (gear).
 - 2 This row shows the amplifier model and the name of the device assigned by Pronet AX. If the device is connected to a Pronet AX network and it is on-line, the row is red, if it's off-line the row is white.
 - 3 This row shows the current loaded preset number and name.
 - 4 This row shows the OUTPUT channels OUT1, OUT2, OUT3, OUT4. In case of bridged channel, OUT2 and OUT4 disappear (Q-NEX5.4 and Q-NEX10.4 only).
 - 5 This row shows the routing of the DSP INPUTS A to D to the outputs channels (single or combined).
 - 6 This meter shows the level of OUTPUTS channels 1, 2, 3, 4.
-  *Note that this level meter may be scaled up if the output peak dynamic control is enabled and set to a lower threshold level to limit the power output: see SPEAKER PROTECTION SETTING and Pronet AX manual for a detailed description.*
- 7 This row shows the name of the each OUTPUT channel assigned by Pronet AX or by recalling a Preset.



- 8 These are the MUTE buttons for each OUTPUT channel: if they are green the channel is unmuted, if they are red the channel is muted. You can mute or unmute each channel by simply touching it or turning the knob and pressing it.
- 9 When the OUTPUT meter turns to YELLOW, this means that the level is about 5 dB below the DSP OUTPUT peak limiter threshold.
- 10 When the OUTPUT meter turn to ORANGE, this means that the level has reached the DSP OUTPUT peak limiter threshold.
- 12 This RED box indicates the intervention of the limit of the correspondent amplifier's output channel.

 *Note that the orange peak signal of the meter can be the same or different from the red box limiter. For example:*
- if the DSP OUTPUT limiter threshold has been set to its maximum value, the orange signal and the red signal correspond;
- if the DSP OUTPUT DSP threshold is set 3 dB below the maximum value to half the output power, the meter reaches orange before the red box.

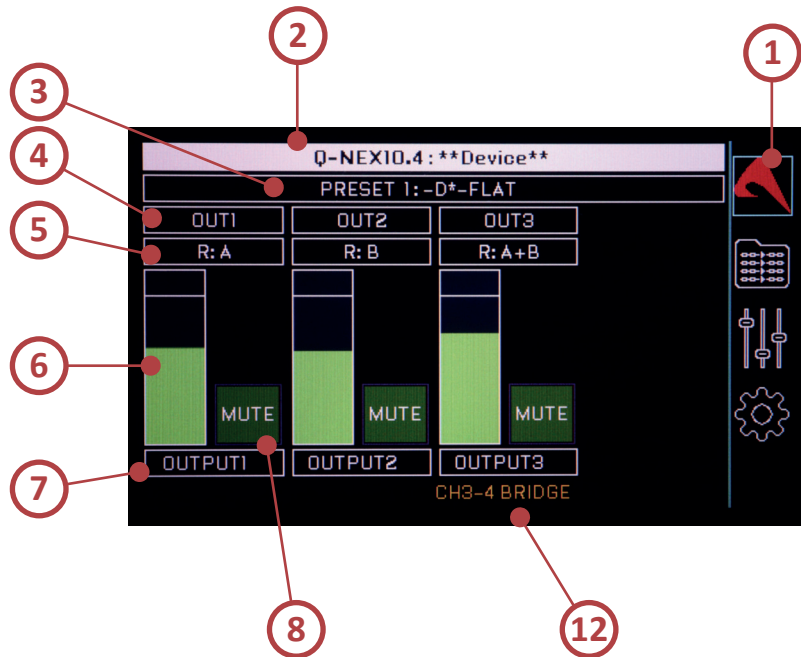

- 13 This text shows that CH1-2 and/or CH3-4 are configured as bridge. The output can be taken from the speakon connector OUT1 and/or OUT3 from terminals 1+ and 2- (Q-NEX5.4 and Q-NEX10.4 only).

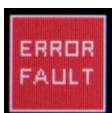

If this text may appear above the mute button on the home screen, it means that something is wrong with the amplifier's power section. The possible causes can be overheating, defective components or a short circuit in the load. Here are some tips that allow you to easily solve the most common problems:

- Remove the output connection to check if there is a short circuit somewhere in the connected cable or the load.
- Check if proper ventilation is ensured for the amplifier during its operation at all times.
- Afterwards, if the warning notice persists, contact AXIOM service centre.



ROUTING PAGE

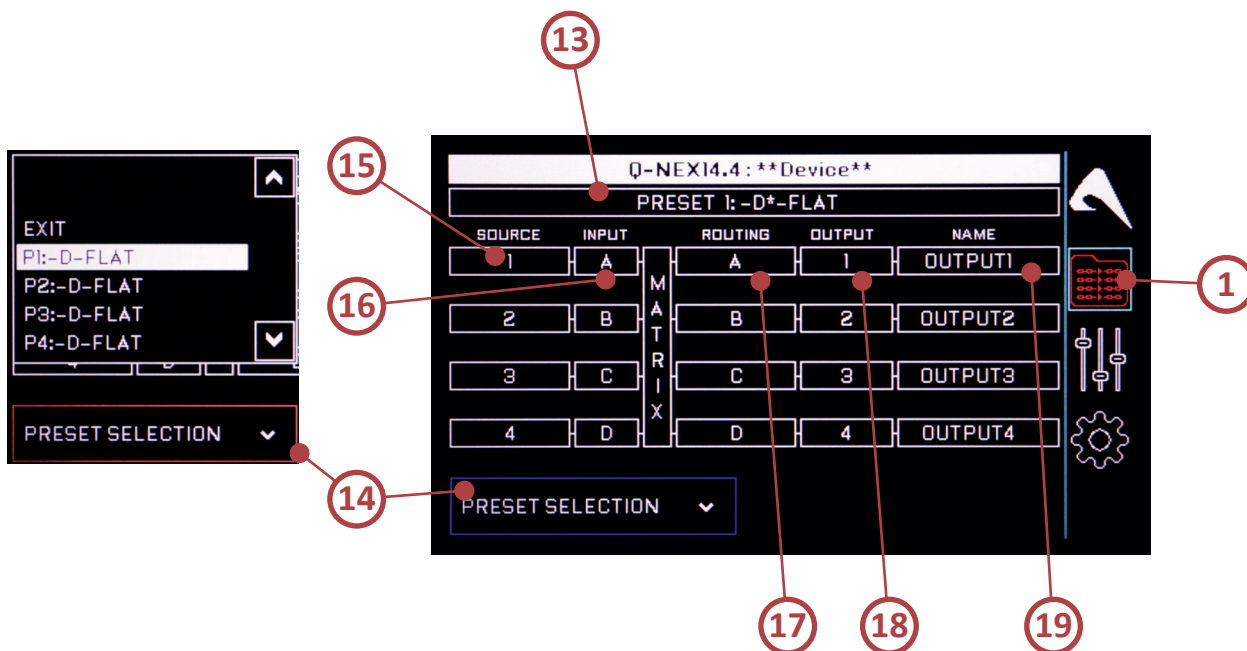

! NOTE: this page displays the current routing of the device. There are no editable parameters here, except for the PRESET selection.

- 13** This row shows the current loaded preset number and its name.
- 14** PRESET SELECTION: touching or selecting this box with dial, you can access the list of presets stored in the device using Pronet AX and recall them.
Note: if you recall a preset from this menu with different Q-NEX devices connected in the same network, even without PRONET AX running, the same preset number will be recalled on all the devices of same model.
- 15** SOURCE: here you can see to which physical input (1/2/3/4) the corresponding DSP INPUT is connected. Physical inputs can be assigned separately or combined together (1+2, 3+4, 1+2+3+4).
- 16** INPUT: here you can see the four DSP INPUTS (A/B/C/D).
- 17** ROUTING: here you can see the ROUTING of the four DSP INPUTS (A/B/C/D) to the four DSP OUTPUTS. The DSP INPUTS can be assigned singularly or combined (A+B, C+D, A+B+C+D).
- 18** Here you can see the four DSP OUTPUTS (1/2/3/4).
- 19** Here you can see the name of the OUTPUT channels specified by Pronet AX or recalling a Preset.

Q-NEX matrix system allows you to assign any physical input from 1 to 4 to any of the four DSP INPUTS A to D, then assign the four DSP INPUTS to any POWER OUTPUT DSP from 1 to 4. Below we report some typical uses:



This example is a typical left and right system with a subwoofer.

- L channel is connected to source 1, then sent to DSP INPUT A
- R channel is connected to source 2, then sent to DSP INPUT B
- L&R channels (source 1&2) are summed and sent to DSP INPUT C
- DSP INPUT A and B are joined
- DSP INPUT A is routed to OUTPUT DSP 1 and then to the amplifier OUTPUT 1 to LEFT SAT
- INPUT DSP B is sent to OUTPUT DSP 2 and then to the amplifier OUTPUT 2 to RIGHT SAT
- DSP INPUT C is sent to OUTPUT DSP 3 and then to the BRIDGE OUTPUT 3 amplifier for the MONO SUB.

With a setting like this you can adjust the level and delay of SAT and SUB separately and optimize your system on the fly without connecting the PRONET AX.

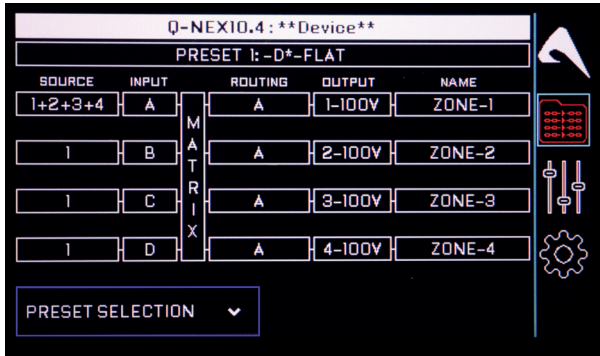

This example is a PA system for a typical large venue that has 4 inputs summed and routed to four zones with different systems, each with its own level, EQ, delay, and so on.

INPUT PAGE

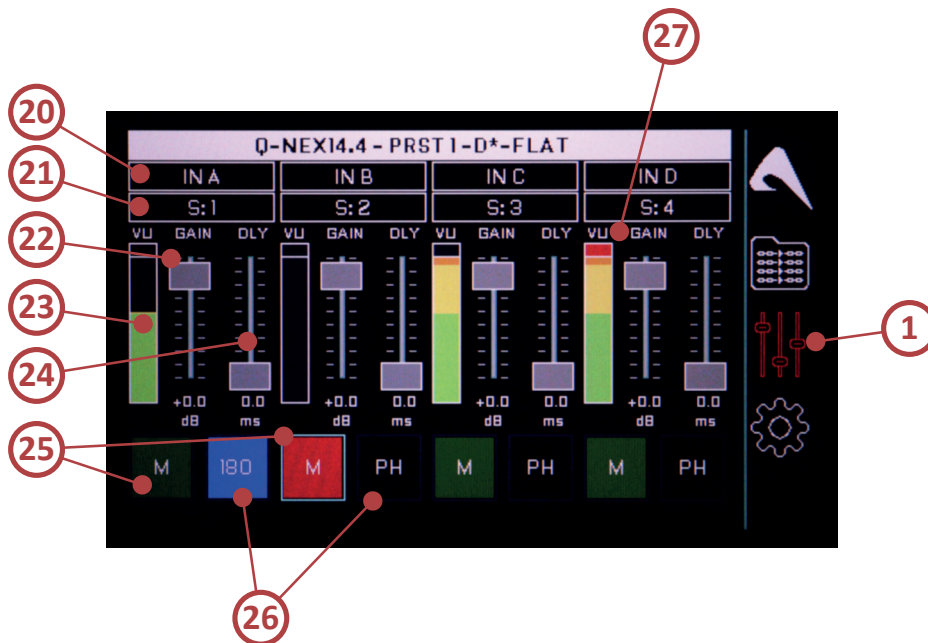

- 20 This row shows the DSP INPUTS IN A, IN B, IN C, IN D.
 - 21 This row shows the current source input (1 to 4) assigned to each A to D DSP INPUTS. The source inputs can be assigned separately or combined together (1+2, 3+4, 1+2+3+4) using Pronet AX.
 - 22 GAIN: this fader allows you to set the INPUT gain of the correspondent DSP INPUTS A to D channel using the DIAL (*NOTE: you can select the fader also by touch, but the adjustment must be done using the dial*).
- !** *Note: this control operates after the AD input conversion.*
- 23 VU: this meter shows the signal level at the DSP input after the GAIN and MUTE controls.
 - 24 DLY: this fader allows you to set the input delay of the correspondent INPUT DSP A to D channel using the DIAL (*NOTE: you can select the fader also by touch, but the adjustment must be done using the dial*).
 - 25 MUTE: this button allows to mute the DSP INPUT A to D. If these are green the channel is unmuted, if these are red the channel is muted. You can mute or unmute each channel by simply touching the button on screen or using the DIAL.
- !** *Note: these buttons mute the DSP inputs and these are different from the OUTPUT mute buttons, see also (9).*
- 26 PH: this button allows to set the phase of the correspondent DSP INPUT A to D. PH (black) indicates that the phase is normal, 180 (blue) indicates that the phase is reversed.
 - 27 CLIP: if this small box at the top end of the VU meter lights up in RED colour the signal at the correspondent source has reached the maximum level available (0dBfs level of the AD input converter), so the input signal must be lowered reducing the output level of the connected device (typically a mixer).



DEVICE PAGE

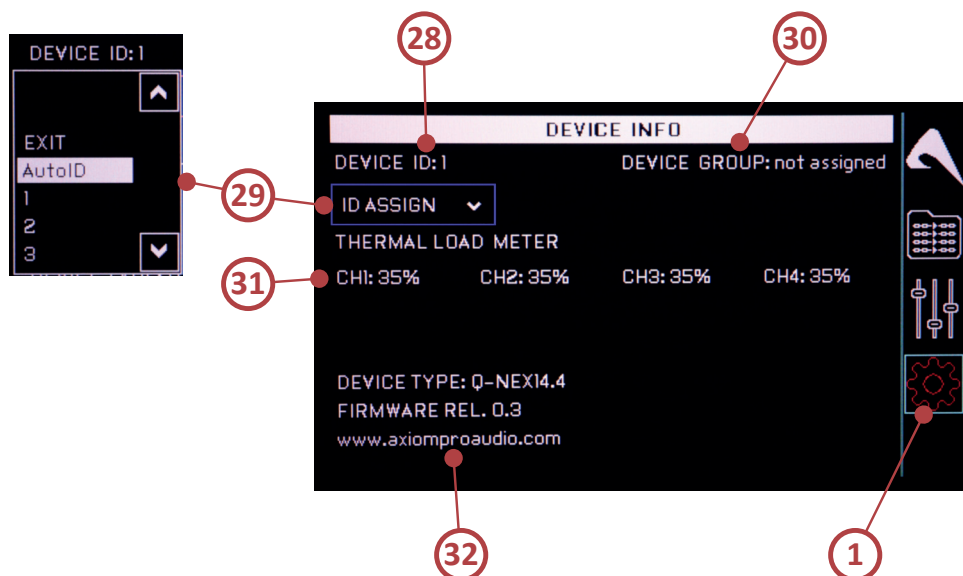

- 28 DEVICE ID: this is the current device ID that allows to locate and communicate with Pronet AX.
- 29 ASSIGN ID: using this function is possible to assign a specific device ID number to the current device: see **PRONET AX section**.
- 30 DEVICE GROUP: using Pronet AX is possible to group devices of the same model. When devices are grouped and the link option is activated in the Pronet AX, when you change a parameter in a device, the same parameters is changed in all devices of same type in the same group (see Pronet AX manual for a detailed explanation).
- 31 THERMAL LOAD METER: this row shows the thermal load for each amplifier channel. The displayed data are in percentage because the temperature is picked up from various sensors on the respective channel. In normal operation, this value must be well below 100% if it reaches the 100% a smoothly reduction of the output power for that channel will be applied to ensure its operational continuity.
- 32 This is where the device model and the firmware version are showed. From the AXIOM website it's possible to download the latest firmware version.

SPEAKER PROTECTION SETTING

If you use Q-NEX amplifiers to drive an AXIOM passive loudspeaker system, the PRESET supplied or downloaded from the website already contains all the protection parameters for the speakers, also if they are not visible by the user, so you need only to recall it using PRONET AX software and store it in the amplifier memory.

If you are using Q-NEX amplifiers to drive another audio system, although it is not possible to protect a speaker from every possible cause that can damage it (such as over-excursion, very unnatural sounding signals or an incorrect setting of the cross-over filter), you may want to know how you can protect the speaker from overheating. You can do that using the **Peak Dynamic Control** contained in the **Edit/OutLevComp** page of PRONET AX.

To protect a speaker from overheating, you need to know some of its technical data:

- The speaker power handling (P_{AES}) measured with the AES2-1984 (r2003) standard (AES Recommended Practice - Specification of loudspeaker components used in professional audio and sound reinforcement), usually it is indicated in the speaker technical data in W_{AES} , this standard is actually the best method to know the power handling capability of the speaker for a standard music program. In case of a group of same kind of speaker connected to the same channel you have to consider the whole power handling.
- The nominal impedance (Z_{NOM}) of the speaker and/or the resulting nominal impedance of the group of speaker connected at the same amplifier channel (typically 4 or 8 ohm).

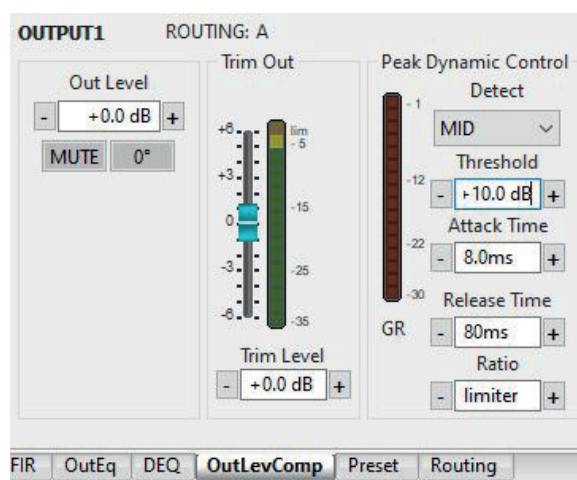

Note: for 70V/100V constant voltage lines all parameters are fixed and not editable.





The Peak Dynamic Control has several parameters to be set properly if you want that it operates as a power limiter:

- **Detect** must be set as MID, this parameter set the speed of the limiter detector.
- **Ratio** must be set as Limiter or at least at 20:1, all ratio below could be not efficient to protect a speaker.
- **Attack Time** and **Release Time** depends on lowest frequency of the loudspeaker to be reproduced without audible artefacts and at same time protect it from excessive power for long time that could damage it. The table below can be used as a starting point, then listen a music program at loud level to adjust them properly avoiding pumping effect or artefacts on the listening material.

Minimum frequency	Attack time (max)	Release time (min)
20 Hz - 63 Hz	45 mS	450 mS
63 Hz - 125 Hz	20 mS	250 mS
125 Hz - 250 Hz	8 mS	130 mS
250 Hz - 500 Hz	4 mS	80 mS
500 Hz - 2K Hz	2 mS	30 mS
2K Hz - 20K Hz	1 mS	10 mS

- **Threshold** must be set to limit the power using the value calculated with the following equation:

$$Peak\ Dynamic\ Threshold_{(dB)} = Input\ Sensitivity_{(dBu)} + 20 * Log_{10} \frac{\sqrt{P_{AES} * Z_{NOM}}}{\sqrt{P_{MAX} * Z_{LOAD}}}$$

where:

$$Input\ Sensitivity_{(dBu)} = +10 (QNEX5.4, QNEX10.4) + 12 (QNEX14.4) + 14 (QNEX20.4).$$

$$P_{AES} = Speaker\ power\ handling\ in\ W_{AES} .$$

$$Z_{NOM} = Speaker\ nominal\ impedance, usually\ 4\ or\ 8\ \Omega .$$

$$P_{MAX} = Maximum\ continuous\ output\ power\ of\ the\ amplifier\ in\ W .$$

$$Z_{LOAD} = Impedance\ of\ the\ load\ for\ the\ specified\ P_{MAX} .$$

example: using a QNEX5.4 capable of deliver 1250W at 8Ω

we want to reduce the power for a speaker capable of handling 100W at 8Ω so:

$$Peak\ Dynamic\ Threshold_{(dB)} = 10 + 20 * Log_{10} \frac{\sqrt{100 * 8}}{\sqrt{1250 * 8}} = -1\ dB$$

SOME TIPS

- To protect the high frequency drivers from dangerous feedbacks in live environments we suggest to set the limiter 3 dB under the calculated value.
- When you push up the volume of your system you can notice that the low-mid content of the program is usually limited before the high-mid content. This is due to the fact that low frequencies activate the limiter before high frequencies, with the result that the system can sound very harsh. In order to restore the original sound balance you can set the HF driver limiter threshold a few dBs (usually 3 - 6) below the calculated value.



PROEL S.p.A. (World Headquarters) - Via alla Ruenia 37/43 - 64027 Sant'Omero (Te) - ITALY
Tel: +39 0861 81241 Fax: +39 0861 887862 www.axiomproaudio.com

